

Pier Luigi Frighetto, 2018

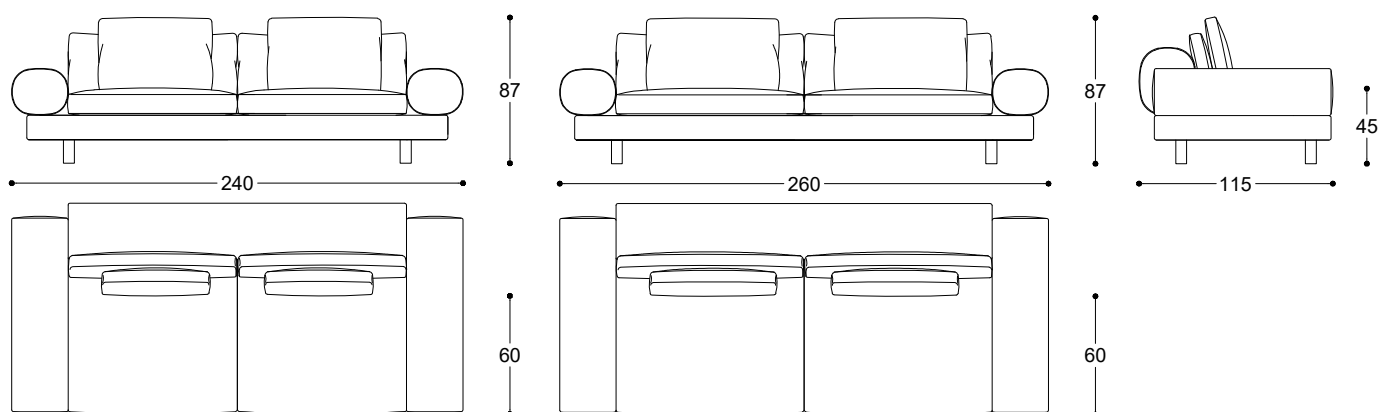

Sofa with structure in poplar wood, with crossed elastic belt spring system. Padding in high-resilience polyurethane foam, upholstery in thermo-bonded fibre with stretch jersey. Seat cushions in 100% European, 10% down, channelled down feather, closed in independent rooms, filling with central insert high-resilience polyurethane foam in different densities and memory foam. Back cushions in 100% European channelled down feather, closed in independent rooms. Fully removable fabric covers, only the cushions for the leather version. Feet in wood, black matt lacquered.

*Divano con struttura in legno di pioppo, con molleggio a nastri elastici intrecciati. Imbottitura struttura in poliuretano espanso ad alta densità, rivestito in fibra termolegata accoppiata a maglina elastica. Cuscini seduta in 100% piuma d'oca di provenienza europea, 10% piumino, chiusi in camere indipendenti l'una dall'altra con inserto di poliuretano espanso a quote differenziate ad alta densità e memory foam. Cuscini schienale in 100% piuma d'oca di provenienza europea, 10% piumino, chiusi in camere indipendenti l'una dall'altra. Completamente sfoderabile in tessuto, in pelle solo i cuscini. Piedini in legno laccato nero opaco.*



Article: Sofa 240  
Code: SEB24

Article: Sofa 260  
Code: SEB26